



FIAS SPECIFICATION SHEET
SAMBO uniform manufacturing

Moscow - 2014

TABLE OF CONTENTS

I. GENERAL PROVISIONS	3
II. TECHNOLOGICAL REQUIREMENTS – SAMBO UNIFORM MANUFACTURING	4
2.1 Jacket	4
2.1.1 Appearance	4
2.1.2 Fabric characteristics	4
2.1.3 Structural features	5
2.1.4 Sizes	5
2.2 Belt	6
2.2.1 Appearance	6
2.2.2 Fabric characteristics	6
2.2.3 Structural features	6
2.2.4 Sizes	6
2.3 Shoes	7
2.3.1 Appearance	7
2.3.2 Fabric characteristics	7
2.3.3 Structural features	7
2.3.4 Sizes	8
2.4 Shorts	8
2.4.1 Appearance	8
2.4.2 Fabric characteristics	8
2.4.3 Structural features	9
2.4.4 Sizes	9
2.5 T-shirt	9
2.5.1 Appearance	9
2.5.2 Fabric characteristics	9
2.5.3 Structural features	10
2.5.4 Sizes	10
III. REQUIREMENTS – POSITION OF LOGOS ON SAMBO UNIFORM	10
3.1 Requirements – manufacturer’s logos	10
3.2 Requirements – FIAS conformity mark	11
APPENDICES	12

Analysis of sporting events arranged by International Sambo Federation (FIAS) shows an increase in modern SAMBO indicators (number of member countries and participants of events, level of preparation and arrangement of events, etc.). However, there are still many issues that remain urgent.

The most important one is about SAMBO uniform, particularly, there is a need to develop unified international standards for uniform and establish regulatory and legal framework for manufacturing, licensing and sale thereof.

The purpose of this project is to develop unified international requirements for SAMBO uniform manufacturing.

I. GENERAL PROVISIONS

Official documents approved by FIAS Executive Committee (Regulations and SAMBO Rules) contain key terms related to SAMBO uniform.

Thus, **Outfit** means sportsman's clothing and gear necessary for training and participation in contests. (Chapter 1, Clause 1 of the Regulations of FIAS on Organizing and Holding Official FIAS Competitions (Sports and Organizational Rules), hereinafter referred to as "FIAS Regulations"). SAMBO uniform is described in FIAS Regulations (Chapter 17, Clause 17.1) as well, according to which:

1. **Uniform of Sambo** competition participant includes:

- SAMBO jacket;
- SAMBO shoes;
- SAMBO shorts.

Besides, the male participants may wear a protective athletic supporter (non-metallic groin-guards) and females may wear the bra and t-shirt (the t-shirt shall be single-colored white);

2. For all official FIAS SAMBO competitions, uniform of a participant and the whole outfit must be of one color – either red or blue. The color of SAMBO shoes may be combined (blue and red). Uniform inspectors shall ensure such compliance.
3. Uniform size compliance is verified by uniform inspectors who use a special ruler in accordance with FIAS competition rules.

II. TECHNOLOGICAL REQUIREMENTS – SAMBO UNIFORM MANUFACTURING

2.1 Jacket

2.1.1 Appearance

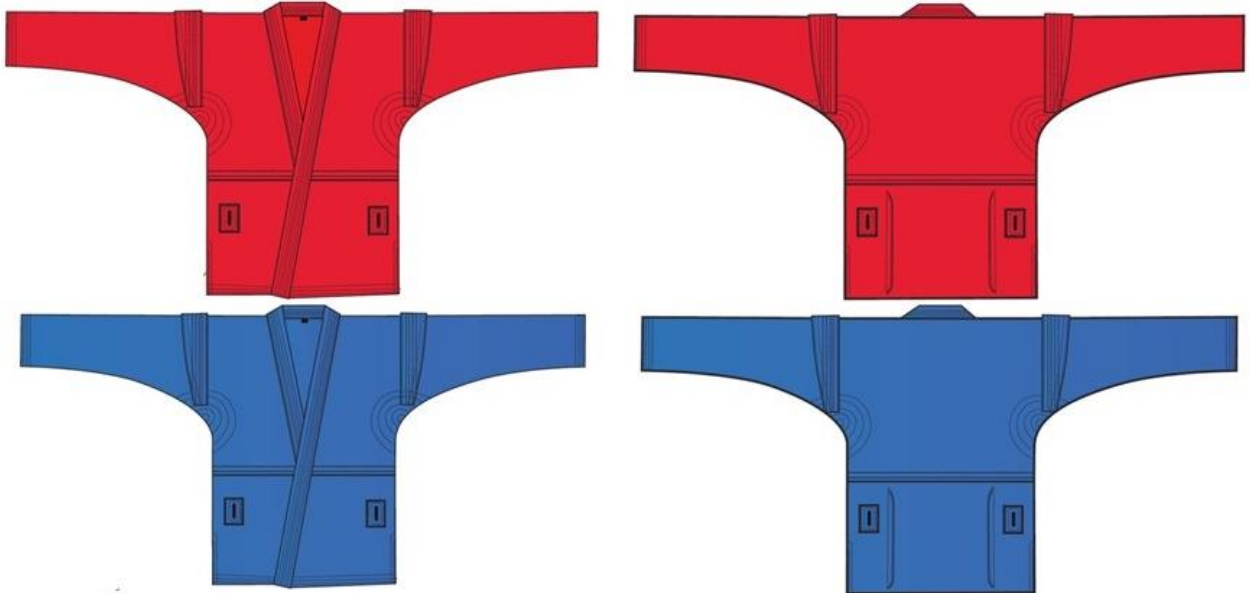

2.1.2 Fabric characteristics

- a) material: cotton at least 80%;
- b) breathable;
- c) (GSM) density: not less than 500 but not more than 700 g/m²;
- d) (Warp/Weft Density) durability: 22 +44 * 20 pcs./inch;
- e) shrinkage <4%;
- f) color (PANTONE international standards):
 - i. red (PANTONE18 -1662TPX (Flame Scarlet));
 - ii. blue (PANTONE18 -4051TPX (Strong Blue));
- g) color permanence: high;
- h) wear resistance: high;
- i) cloth texture is homogeneous dense double twisted cotton thread.

There can be two types of textures:

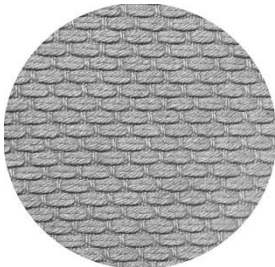
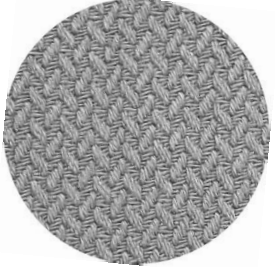
"Rice Grain"	"Herringbone"
	

2.1.3 Structural features

SAMBO jacket consists of two pieces of fabric with a wrap, without lining.

- a) the upper part of the jacket is made from one piece of fabric;
- b) the collar is stiff, made from one piece of fabric: width 4-5 cm, 5 rows of stitching;
- c) special shoulder “wing” panels are made of twice-folded main fabric: width is 2-3 cm on edges, and 5-6 cm in the midst, with 4-5 rows of stitching;
- d) the lower part of the jacket is made from one piece of fabric, has holes and cuts:
 - i. there are holes on the waist line for a belt (2 on front panel, 2 on back panel): hole width is 0.5-1 cm, height 5 cm;
 - ii. cuts go half way up the side lines (of the lower part of a jacket).
- e) reinforced (strengthened) jacket parts (**Appendix 1**):
 - i. there is an oval patch on the arm-holes made of main fabric, stitched from the inside;
 - ii. side slits bottom of the jacket are reinforced by the strip of the main fabric and sewn on the inside - width 1-2. 5 cm, at least 3 rows of stitching;
 - iii. edge of the sleeves and bottom of jacket are reinforced by the strip or by tucking the main fabric - width 2 cm, at least 2 rows of stitching;
 - iv. the upper and lower parts of the jacket are stitched together using the “lock” seam or special banding from the inside, width: 1.5-2.5 cm, at least 3 rows of stitching;
 - v. slits for a belt are reinforced with a square patch from the outside: width 1.5-2 cm larger than each side of the slit, at least 3 rows of stitching.

The basic configuration of the seams on the jacket SAMBO presented in **Appendix 2**.

2.1.4 Sizes

SAMBO jacket shall correspond to international standard clothing sizes for men.

US Size	SS	XS	S	M	L	XL	XXL	3XL	4XL	5XL	6XL
EU Size	42	44	46	48	50	52	54	56	58	60	62
Height (cm)	150	155	160	165	170	175	180	185	190	195	200

2.2 Belt

2.2.1 Appearance

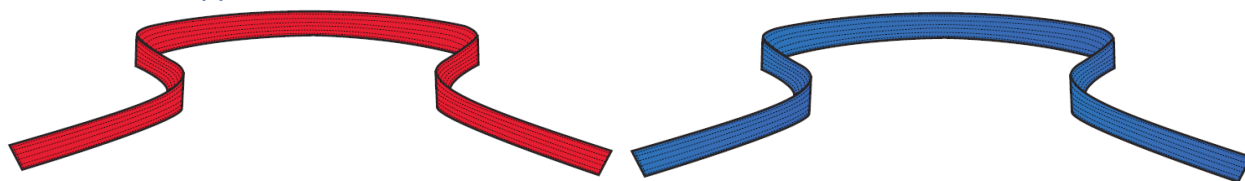

2.2.2 Fabric characteristics

- a) material: cotton at least 80%;
- b) thread count (SPEC) 10S / 5 +21 S / 2 * 10S / 1;
- c) (GSM) density: not less than 500 but not more than 700 g/m²;
- d) (Warp/Weft Density) durability: 22 +44 * 20 pcs. / inch;
- e) shrinkage <4%;
- f) color (PANTONE international standards):
 - i. red (PANTONE18 -1662TPX (Flame Scarlet));
 - ii. blue (PANTONE18 – 4051TPX (Strong Blue));
- g) color permanence: high;
- h) wear resistance: high;
- i) cloth texture is homogeneous dense double twisted cotton thread.

2.2.3 Structural features

SAMBO belt is made of one piece of main fabric (same as the jacket). The width of a finished belt is 4-5 cm. The band of fabric is folded 3-4 times. The belt has 6-8 rows of stitching along its length, placed 0.5 cm from each other.

The configuration of the seams on the jacket SAMBO presented in **Appendix 2**.

2.2.4 Sizes

Belts for SAMBO jackets shall correspond to SAMBO jacket sizes.

US Size	SS	XS	S	M	L	XL	XXL	3XL	4XL	5XL	6XL
EU Size	42	44	46	48	50	52	54	56	58	60	62
Length (cm)	240	250	260	280	280	300	300	320	320	340	340

2.3 Shoes

2.3.1 Appearance



2.3.2 The characteristic of the fabric and the choice of materials used for the production of SAMBO shoes, determined by the manufacturer. It is necessary to consider the requirements of the FIAS, the main of which are:

- a) color (PANTONE international standards):
 - i. red (PANTONE18 -1662TPX (Flame Scarlet));
 - ii. blue (PANTONE18 – 4051TPX (Strong Blue));
- b) shrinkage <4%;
- c) color permanence: high;
- d) wear resistance: high;

2.3.3 Structural features

Design features of the SAMBO shoes are determined by the manufacturer, but it is necessary to consider the requirements of the FIAS, the main of which are:

- a) ready-to-wear model shall be anatomic, light, soft, without any rough, coarse or protruding elements and seams;
- b) all seams shall be closed up inside;
- c) ankles and feet at the big toe joint shall be protected by small felt pads;

- d) boot-top height shall be 5-10 cm from the lower part of the lateral (external) part of the ankle;
- e) boot-top form may be straight or oblique;
- f) after lacing the shoes, boot-top must be tightly fitted around the ankles;
- g) tongue height shall not exceed the height of boot-top by more than 1 cm.

2.3.4 Sizes

SAMBO shoes shall correspond to international standard shoe sizes for men.

US Size	3	4	5	6	7	8	9	10	11	12	13
EU Size	35	36	37	38	40	41	42	44	45	46	47

2.4 Shorts

2.4.1 Appearance:

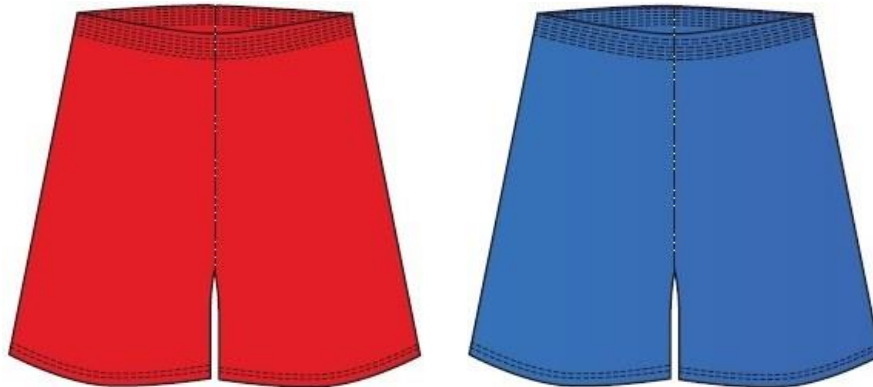

2.4.2 Fabric characteristics:

- a) material: jersey with synthetic fibers;
- b) durability: high;
- c) breathability: high;
- d) shape stability: high;
- e) color (PANTONE international standards):
 - i. red (PANTONE18 -1662TPX (Flame Scarlet));
 - ii. blue (PANTONE18 – 4051TPX (Strong Blue));
- f) color permanence: high;
- g) wear resistance: high;
- h) fabric texture is homogeneous, dense, breathable, water absorbing, with great elasticity, preserves its shape, does not crease.

2.4.3 Structural features

Design features of the SAMBO shorts are determined by the manufacturer, but it is necessary to consider the requirements of the FIAS, the main of which are:

- a) shorts shall be slim-lined; they should not constrain any movement;
- b) shorts shall have an adjustable drawcord;
- c) all seams shall be closed up inside, internal finishing – overlock;
- d) cover-seaming shall be used for hems;
- e) holes are finished using buttonhole machine;
- f) length of shorts is mid-thigh.

2.4.4 Sizes

SAMBO shorts shall correspond to international standard clothing sizes for men.

US Size	SS	XS	S	M	L	XL	XXL	3XL	4XL	5XL	6XL
EU Size	42	44	46	48	50	52	54	56	58	60	62
Height (cm.)	150	155	160	165	170	175	180	185	190	195	200

2.5 T-shirt (for women)

2.5.1 Appearance:

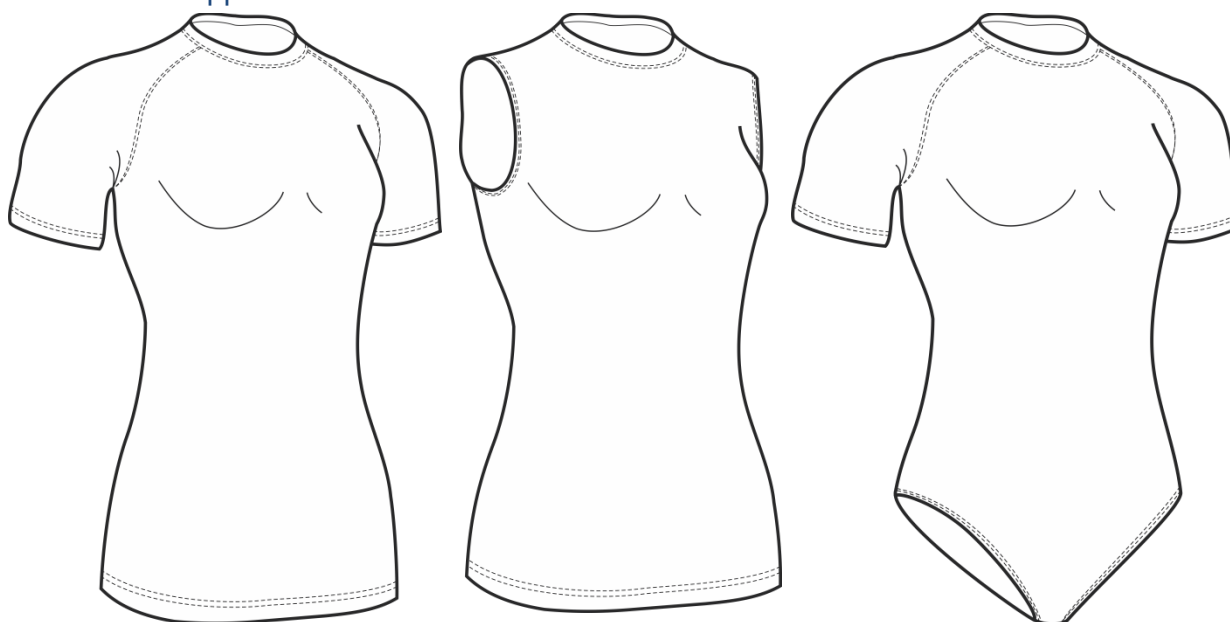

2.5.2 Fabric characteristics:

- a) material: knitted fabric with synthetic fibers;
- b) color (PANTONE international standards):
 - i. white (PANTONE11-0601 (White));
- c) color permanence: high;

- d) fabric texture is homogeneous, dense, air-permeable, water absorbing, with great elasticity, preserves its shape, does not crease.

2.5.3 Structural features

Design features of the t-shirt are determined by the manufacturer, but it is necessary to consider the requirements of the FIAS, the main of which are:

- a) the fit should be tight-fitting, anatomical, without rough seams;
- b) all seams and folds on the treated interlock machine;
- c) width of t-shirt collar is 1-2 cm.;
- d) t-shirt can be made in the usual style or type of body without sleeve or short sleeve;
- e) if the t-shirt has the type of body, the buckle must be in the form of hook and loop fasteners (VELCRO).

2.5.4 Sizes

T-shirt shall correspond to international standard clothing sizes for women.

US Size	SS	XS	S	M	L	XL	XXL
EU Size	42	44	46	48	50	52	54

III. REQUIREMENTS – LOGO PLACEMENT ON SAMBO UNIFORM

The manufacturer shall place its own logo and conformity mark of FIAS on SAMBO jacket, shorts, shoes and t-shirt in strict compliance with the present Provision.

3.1 Requirements for manufacturer’s logos

3.1.1 Main requirements for placement of manufacturer’s logo on SAMBO uniform are as follows:

- a) manufacturer’s logo shall be placed on the front left side of the SAMBO jacket at the bottom right of the snip;
- b) manufacturer’s logo shall be placed on the SAMBO belt from one end, located in the center across the width of a lapel;
- c) manufacturer’s logo shall be placed on the SAMBO shorts at the bottom, on the left side at the side seam;
- d) manufacturer’s logo shall fit the circle pads in the ankle area on the inside of a shoe;
- e) manufacturer’s logo shall be placed on the t-shirt, at the the chest, on the left side.

3.1.2 The manufacturer's logo must be made of non-toxic materials, in the form of sublimation, transfer printing, screen printing, embroidery or other method of application, have a high wear resistance and no sharp, rough elements that may cause damage. On the t-shirt, the manufacturer logo must be made only by a sublimation method.

3.1.3 Logo shall be placed vertically or horizontally.

3.1.4 The size of the logo area must not exceed 18 cm².

3.1.5 The principle of applying manufacturer logo on the SAMBO uniform is shown in **Appendix 3**.

3.2 Requirements for placement of FIAS conformity mark

3.2.1 Main requirements for placement of FIAS conformity mark on SAMBO uniform are as follows:

- a) on the jacket conformity mark shall be placed on the end (bottom) of the left lapel;
- b) on the belt conformity mark shall be placed at on one end and on the same side (surface) as a manufacturer logo;
- c) on the shorts conformity mark shall be placed on the top, on the right side of the side seam;
- d) on the shoes conformity mark should be placed on the "tongue" of both shoes in the upper part, centered;
- e) on the t-shirt conformity mark shall be placed on the top, on center back below the collar.

3.2.2 The FIAS conformity mark must be made of non-toxic materials, in the form of sublimation, transfer printing, screen printing, embroidery or other method of application, have a high wear resistance and no sharp, rough elements that may cause damage. On the t-shirt, the FIAS conformity mark must be made only by a sublimation method.

3.2.3 The principle of applying conformity mark of FIAS on the SAMBO uniform is shown in **Appendix 3**.

Strengthening (reinforcement) details of the jacket using the main fabric and reinforced stitching lines.

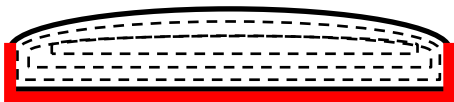
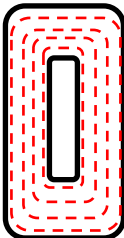
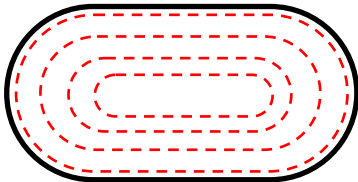
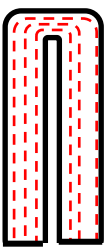

<p>I</p>		<p>Special bar "wings" are attached to the jacket outside. Sewn "wings" on three sides, reinforced sewing stitch.</p>
<p>II</p>		<p>Slits for belt amplified rectangular patch and fastened to the jacket outside. Sewn along the perimeter reinforced sewing lines.</p>
<p>III</p>		<p>Oval patches are attached to the jacket with the inner side in the area of the armhole. Sewn perimeter reinforced sewing lines.</p>
<p>IV</p>		<p>Incisions in the lateral line of jackets, inside amplified by the strip of the main fabric. Sewn perimeter reinforced sewing lines.</p>

Configuration seam detail jacket and belt SAMBO

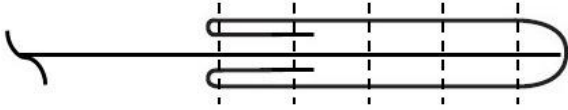
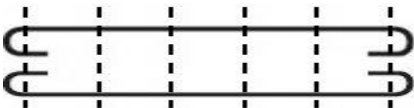
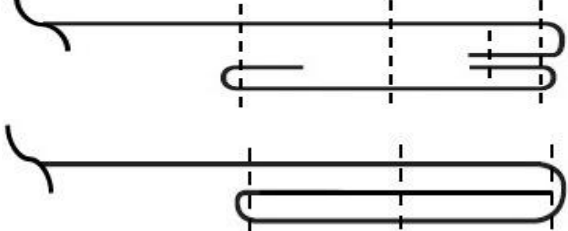
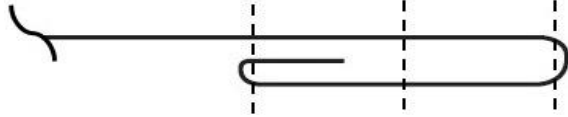
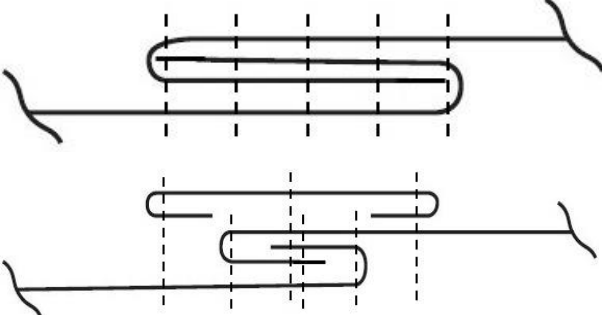
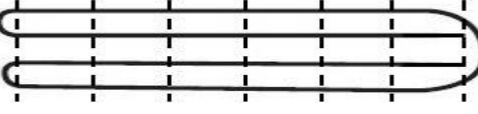
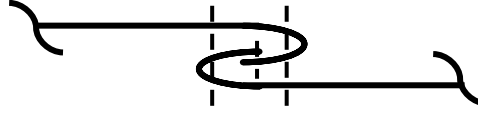
Seam Configuration	Seam Purpose
	<p>For sewing gate SAMBO jacket. The width of the gate 4 cm. has 5-7 sewing lines.</p>
	<p>For sewing "wings". Made from the main fabric in two layers. Width 2-3 cm. with all, and 5-cm. in the middle, has 4-6 sewing lines.</p>
	<p>To enhance lateral incisions jacket or edges sleeve stripe. The edges of the sleeves can be improved flexion of the main fabric with a shut cut. Width 2 cm., at least 2 of the sewing lines.</p>
	<p>To handle the lower edges of the jacket and shorts. Width - to 2 cm., at least 2 of the sewing lines.</p>
	<p>To connect the top and bottom of the jacket. Amplified through the suture lock or strip-tape on the inside of the jacket. Width of 1.5-2.5 cm., at least 3 of the sewing lines.</p>
	<p>For sewing SAMBO belt. The width of the finished belt 4-5 cm. fabric Strip is folded in 3-4 layers. Prestratified belt length (along), the number of sewing lines 6-8, located at a distance of 0.5 cm. relative to each other.</p>
	<p>For stitching sleeveless length. The width of 1-1,5 cm., at least 2 of the sewing lines.</p>

The principle of FIAS conformity mark and manufacturer logos placement on the SAMBO uniform

